

**Závitové kruhové
čelisti
Circular dies
Schneideisen
Плашки**

Unifikovaný extra jemný závit
Unified extra fine thread
Unified-Extra-Feingewinde
Унифицированная экстра
мелкая резьба

UNEF

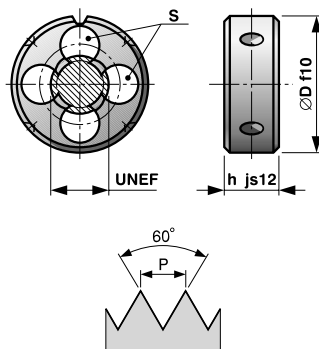

1,5P

	z/1"	P	D	h	S		code ^{*)}
12	32	0,794	20	7	4	5,42	XXX 012
1/4	32	0,794	20	7	4	6,22	XXX 140
5/16	32	0,794	25	9	4	7,82	XXX 516
3/8	32	0,794	30	11	4	9,42	XXX 380
7/16	28	0,907	30	11	5	10,98	XXX 716
1/2	28	0,907	38	10	5	12,53	XXX 120
9/16	24	1,058	38	10	5	14,13	XXX 916
5/8	24	1,058	45	14	5	15,73	XXX 580
11/16	24	1,058	45	14	5	17,30	XXX 111
3/4	20	1,270	45	14	6	18,95	XXX 340
13/16	20	1,270	45	14	6	20,50	XXX 131
7/8	20	1,270	55	16	5	22,10	XXX 780
15/16	20	1,270	55	16	6	23,65	XXX 151
1	20	1,270	55	16	6	25,25	XXX 100

^{*)} 248 XXX - HSS

^{*)} 278 XXX - HSS s lamačem třísek / with spiral point / mit Schälanschnitt / с ломателем стружек

*Materiál: HSS;
NO, HSSE - dle požadavku
Provedení: závit lapovaný
Závit: pravý
Lícování: 2A*

*Material: HSS;
CS, HSSE - on request
Execution: lapped thread
Thread: right-hand
Tolerance: 2A*

*Werkstoff: HSS;
WS HSSE - nach dem
Anspruch
Ausführung: geläpftes Gewinde
Gewinde: rechts
Toleranz: 2A*

*Материал: HSS;
NO, HSSE - по заказу
Изготовлено: резьба
шлифованная
Резьба: правая
Подгонка: 2A*

