

HSS

HSSE

TiN

**BUČOVICE  
TOOLS**

**Stupňovité vrtáky**  
**Stepped peeling drills**  
**Stufenbohrer**  
**Ступенчатые свёрла**

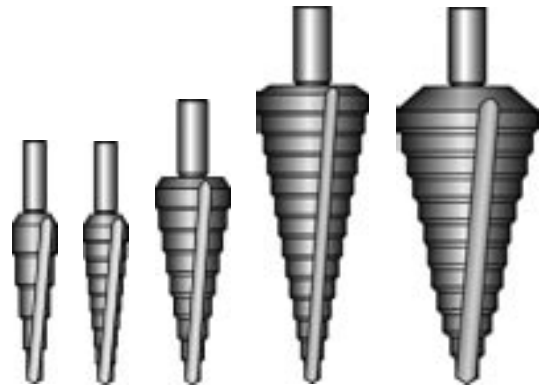
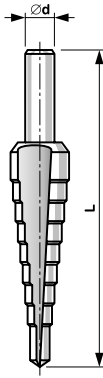

Velikost/Size/Größe/Размер	Ø D	Ø d	L	code HSS	code HSSE
4/12-2	4; 6; 8; 10; 12	6	65	641 005	691 005
4/12-1	4; 5; 6; 7; 8; 9; 10; 11; 12	6	65	641 009	691 009
4/20	4; 6; 8; 10; 12; 14; 16; 18; 20	8	75	641 010	691 010
4/30	4; 6; 8; 10; 12; 14; 16; 18; 20; 22; 24; 26; 28; 30	13	100	641 015	691 015
5/35	5; 7,5; 10; 13; 16; 19; 21; 23; 26; 29; 31; 33; 35	13	100	641 025	691 025
6/30	6; 8; 10; 12; 14; 16; 18; 20; 22; 24; 26; 28; 30	10	100	641 020	691 020
6/24	6; 8; 10; 12; 14; 16; 18; 20; 22; 24	10	85	641 013	691 013
6/38	6; 9; 13; 16; 19; 21; 23; 26; 29; 32; 35; 38	10	100	641 030	691 030
7/30	7; 9; 11; 13,5; 16; 21; 30,5	13	85	641 028	691 028
10/20	10; 11; 12; 13; 14; 15; 16; 17; 18; 19; 20	10	82	641 027	691 027
20/30	20; 21; 22; 23; 24; 25; 26; 27; 28; 29; 30	13	88	641 031	691 031

Velikost/Size/Größe/Размер	Ø D	Ø d	L	code HSS TiN	code HSSE TiN
4/12-2 TiN	4; 6; 8; 10; 12	6	65	646 005 TiN	696 005 TiN
4/12-1 TiN	4; 5; 6; 7; 8; 9; 10; 11; 12	6	65	646 009 TiN	696 009 TiN
4/20 TiN	4; 6; 8; 10; 12; 14; 16; 18; 20	8	75	646 010 TiN	696 010 TiN
4/30 TiN	4; 6; 8; 10; 12; 14; 16; 18; 20; 22; 24; 26; 28; 30	13	100	646 015 TiN	696 015 TiN
5/35 TiN	5; 7,5; 10; 13; 16; 19; 21; 23; 26; 29; 31; 33; 35	13	100	646 025 TiN	696 025 TiN
6/30 TiN	6; 8; 10; 12; 14; 16; 18; 20; 22; 24; 26; 28; 30	10	100	646 020 TiN	696 020 TiN
6/24 TiN	6; 8; 10; 12; 14; 16; 18; 20; 22; 24	10	85	646 013 TiN	696 013 TiN
6/38 TiN	6; 9; 13; 16; 19; 21; 23; 26; 29; 32; 35; 38	10	100	646 030 TiN	696 030 TiN
7/30 TiN	7; 9; 11; 13,5; 16; 21; 30,5	13	85	646 028 TiN	696 028 TiN
10/20 TiN	10; 11; 12; 13; 14; 15; 16; 17; 18; 19; 20	10	82	646 027 TiN	696 027 TiN
20/30 TiN	20; 21; 22; 23; 24; 25; 26; 27; 28; 29; 30	13	88	646 031 TiN	696 031 TiN

Materiál: HSS; HSSE; TiN

Material: HSS; HSSE; TiN

Werkstoff: HSS; HSSE; TiN

Mamepuan: HSS; HSSE; TiN

**HSS HSSE****BUČOVICE TOOLS**

**Stupňovité vrtáky PG**  
**Stepped peeling drills PG**  
**Stufenbohrer PG**  
**Ступенчатые свёрла PG**

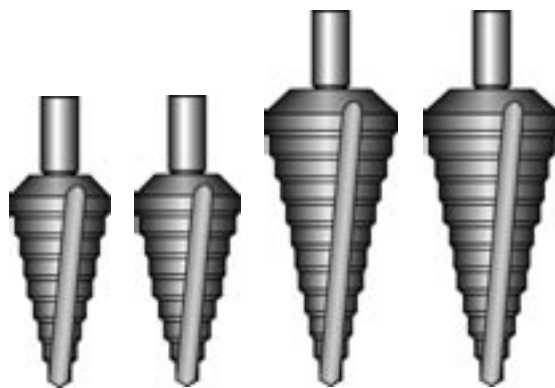
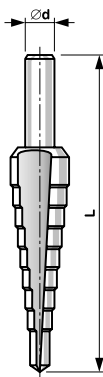

Velikost/Size/Grösse/Размер	Ø D	Ø d	L	code HSS	code HSSE
PG 1	6; 9; 11,4; 14; 17,25; 19; 21,25; 26,75	10	77	642 010	692 010
PG 2	6; 9; 12,5; 15,2; 18,6; 20,4; 22,5; 28,3	10	77	642 020	692 020
PG 3	6; 9; 11,4; 14; 17,25; 19; 21,25; 24; 26,75; 30; 33; 35,7	10	100	642 030	692 030
PG 4	6; 9; 12,5; 15,2; 18,6; 20,4; 22,5; 26; 28,3; 30,5; 34; 37	10	100	642 040	692 040

Materiál: HSS; HSSE

Material: HSS; HSSE

Werkstoff: HSS; HSSE

Mamepuan: HSS; HSSE

**HSS****BUČOVICE TOOLS**

**Stupňovité vrtáky - bit**  
**Stepped peeling drills - bits**  
**Stufenbohrer - Bits**  
**Ступенчатые свёрла - ВИТЫ**

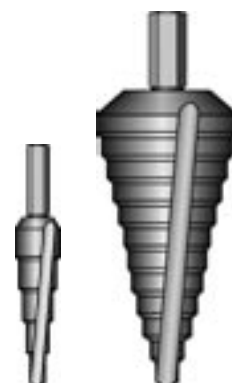
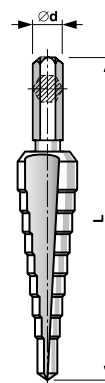

Velikost/Size/Grösse/Размер	Ø D	Ø d	L	code
4/12	4; 6; 8; 10; 12	1/4"	54	643 012
5/13	5; 7; 9; 11; 13	1/4"	54	643 013
8/20	8; 10; 12; 14; 16; 18; 20	1/4"	67	643 020
9/21	9; 11; 13; 15; 17; 19; 21	1/4"	67	643 021

Materiál: HSS; HSSE

Material: HSS; HSSE

Werkstoff: HSS; HSSE

Mamepuan: HSS; HSSE